

# 單段立式馬達直結減速機- UTE系列

Single-stage direct motor coupled vertical reducer - UTE series

◀ Type: UTE ▶



UTE60-100

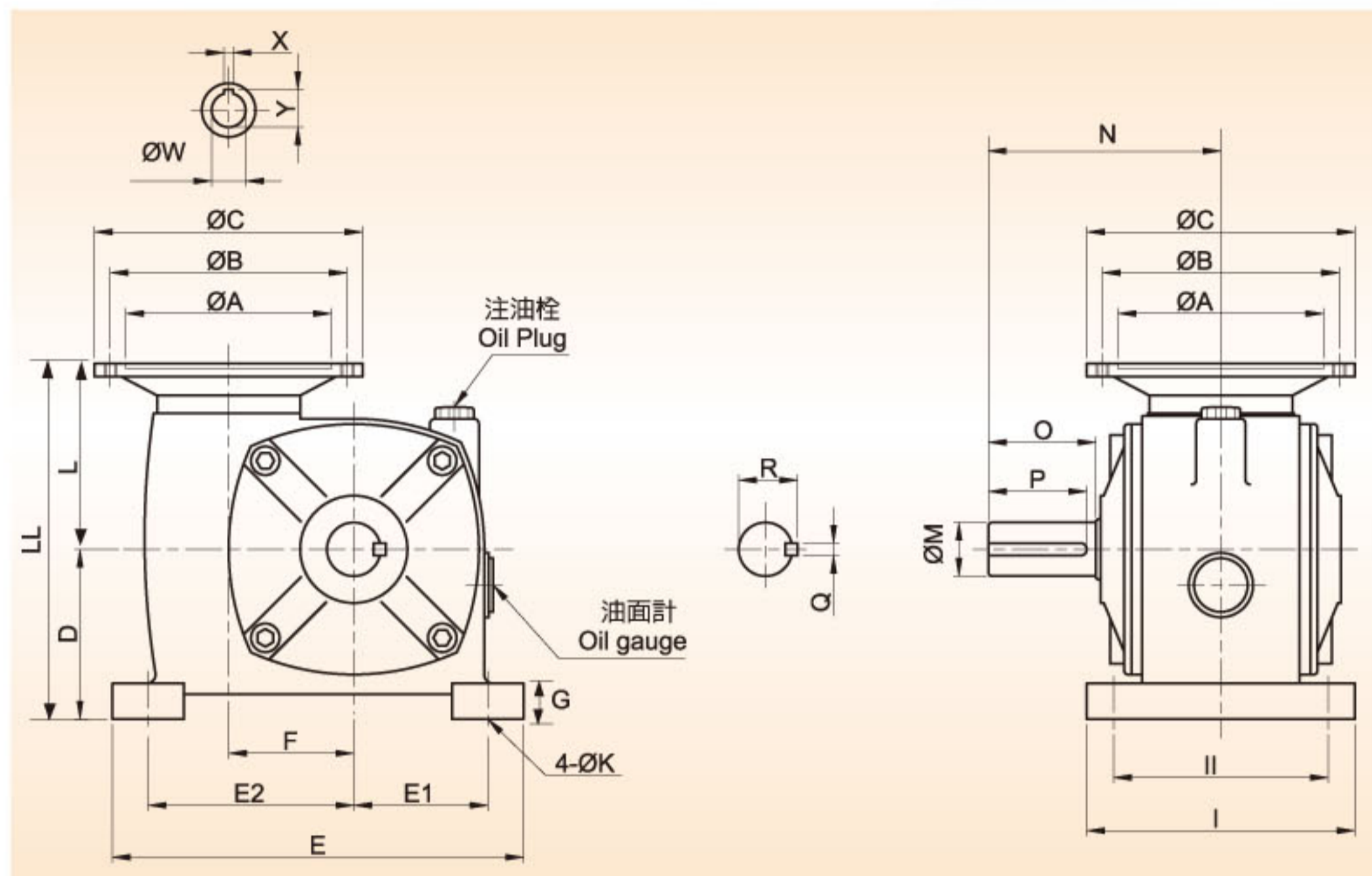

## 尺寸表 Dimensions

型號 SIZE	LL	L	D	N	F	E1	E2	E	II	I	K	G
60	162	72	78	110	60	64	96	205	100	130	11	20
70	193	95	95	130	70	75	115	235	120	150	15	20
80	219	105	105	140	80	90	125	264	125	160	15	20
100	297	144	135	170	100	100	150	310	155	195	15	25
120	330	170	160	190	120	120	180	360	180	230	18	28

型號 SIZE	馬力 HP		馬達盤 MOTOR FLANGE				入力孔 INPUT BORE			出力軸 OUTPUT SHAFT					重量 (Kg)
	1/10~ 1/30	1/40~ 1/60	A	B	C	Z	W	X	Y	O	P	M	Q	R	
60	1/2	1/4	110	110	160	M8	11 14	4 5	12.5 16	50	45	22	7	25	12
70	1	1/2	110	130	160	M8	14	5	16	60	55	28	7	31	15
			130	165	200	M10	19	6	21.5						
80	2	1	130	165	200	M10	19	6	21.5	65	60	32	10	35.5	22
							24	8	27						
100	3	2	130	165	200	M10	24	8	27	75	70	38	10	41.3	42
			180	215	250	M12	28	8	30.9						
120	5	3	180	215	250	M12	28	8	30.9	85	80	45	12	48.2	-

## 軸配置及旋轉方向 Shaft Arrangement and Rotation Direction

