

單段立式馬達直結減速機—BE系列

Single-stage direct motor coupled vertical reducer - BE series

◀ Type: **BE** ▶



BE50-250

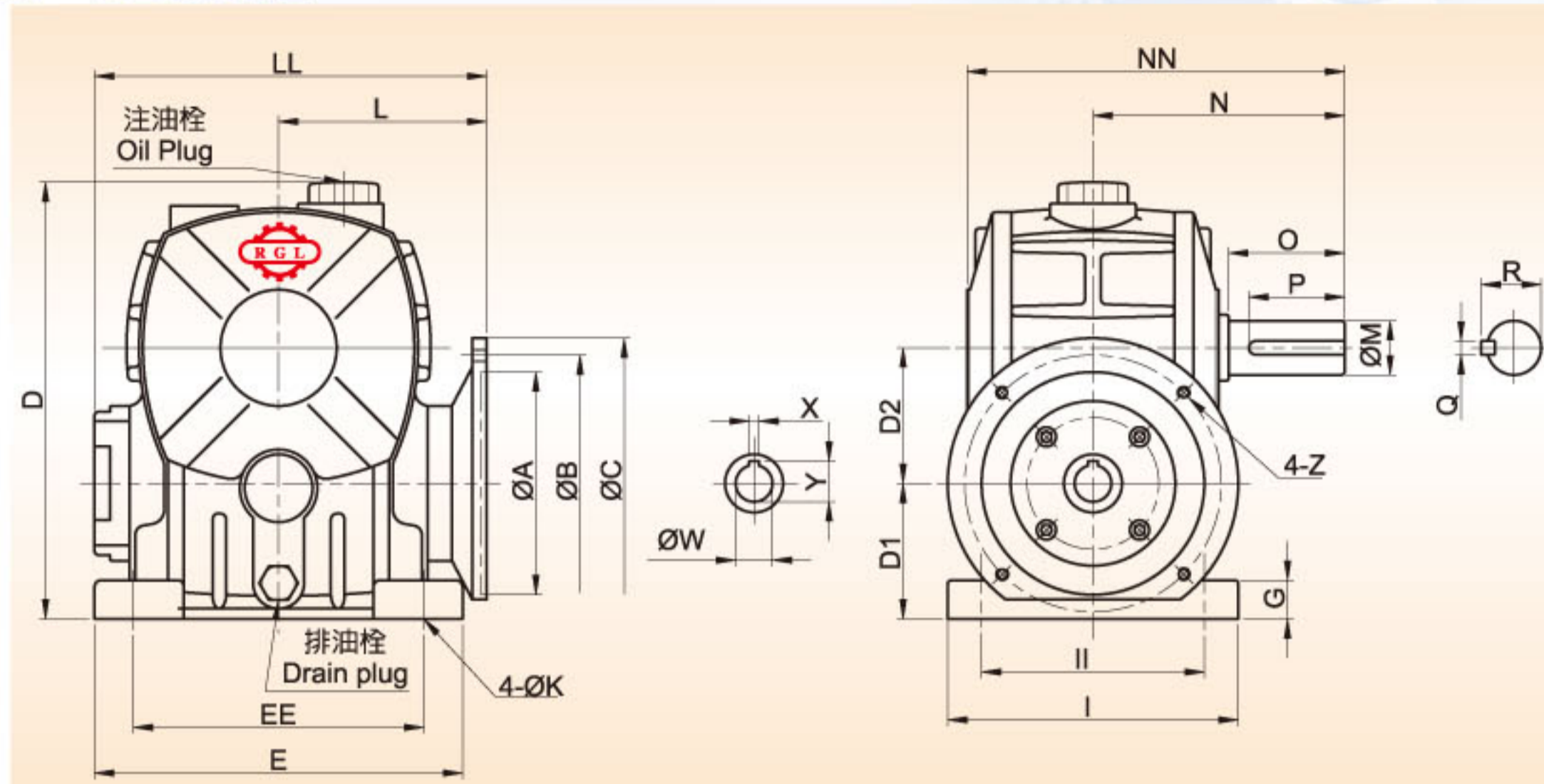

尺寸表 Dimensions

型號 SIZE	LL	L	NN	N	D1	D2	D	EE	E	II	I	G	K
50	154	81	145	95	50	50	174	110	140	95	120	15	11
60	160	85	165	110	60	60	197	120	150	105	130	20	11
70	196	102	195	130	70	70	236	150	190	115	150	20	15
80	217	113	210	140	80	80	265	180	220	135	170	20	15
100	280	148	260	170	100	100	362	220	270	155	190	25	15
120	318	165	290	190	120	120	424	260	320	180	230	30	18
135	367	188	320	210	135	135	481	290	350	200	250	30	18
155	397	208	387	252	135	155	512	320	380	220	280	36	20
175	445	223	407	262	160	175	577	350	410	250	310	37	20
200	494	256	480	305	175	200	650	350	420	290	360	42	22
225	555	285	524	335	190	225	702	390	460	330	410	45	27
250	610	315	560	360	200	250	755	440	520	380	460	50	27

型號 SIZE	馬力 HP		馬達盤 MOTOR FLANGE				入力孔 INPUT BORE			出力軸 OUTPUT SHAFT					重量 (Kg)
	1/10~1/30	1/40~1/60	A	B	C	Z	W	X	Y	O	P	M	Q	R	
50	1/4	1/8	110	130	160	M8	11	4	12.5	40	35	17	5	19	9
60	1/2	1/4	110	130	160	M8	11	4	12.5	50	45	22	7	25	11
70	1	1/2	110 130	130 165	160 200	M8 M10	14 19	5 6	16 21.5	60	55	28	7	31	15
80	2	1	130	165	200	M10	19 24	6 8	21.5 27	65	60	32	10	35.5	26
100	3	2	130 180	165 215	200 250	M10 M12	24 28	8	27 31	75	70	38	10	41.5	36
120	5	3	180	215	250	M12	28	8	31	85	80	45	12	48.5	62
135	7-1/2	5	180 230	215 265	250 300	M12	28 38	8 10	31 41	95	90	55	15	60	91
155	10	7-1/2	230	265	300	M12	38	10	41	110	105	60	15	65	110
175	15	10	230 250	265 300	300 350	M12 M16	38 42	10 12	41 45	110	105	65	18	71	165
200	20	15	250	300	350	M16	42	12	45	125	120	70	20	76	220
225	25	20	250 300	300 350	350 400	M16	42 48	12 14	45 51.5	140	135	80	20	86	285
250	30	25	300	350	400	M16	48	14	51.5	155	150	90	24	98	335

軸配置及旋轉方向 Shaft Arrangement and Rotation Direction

