

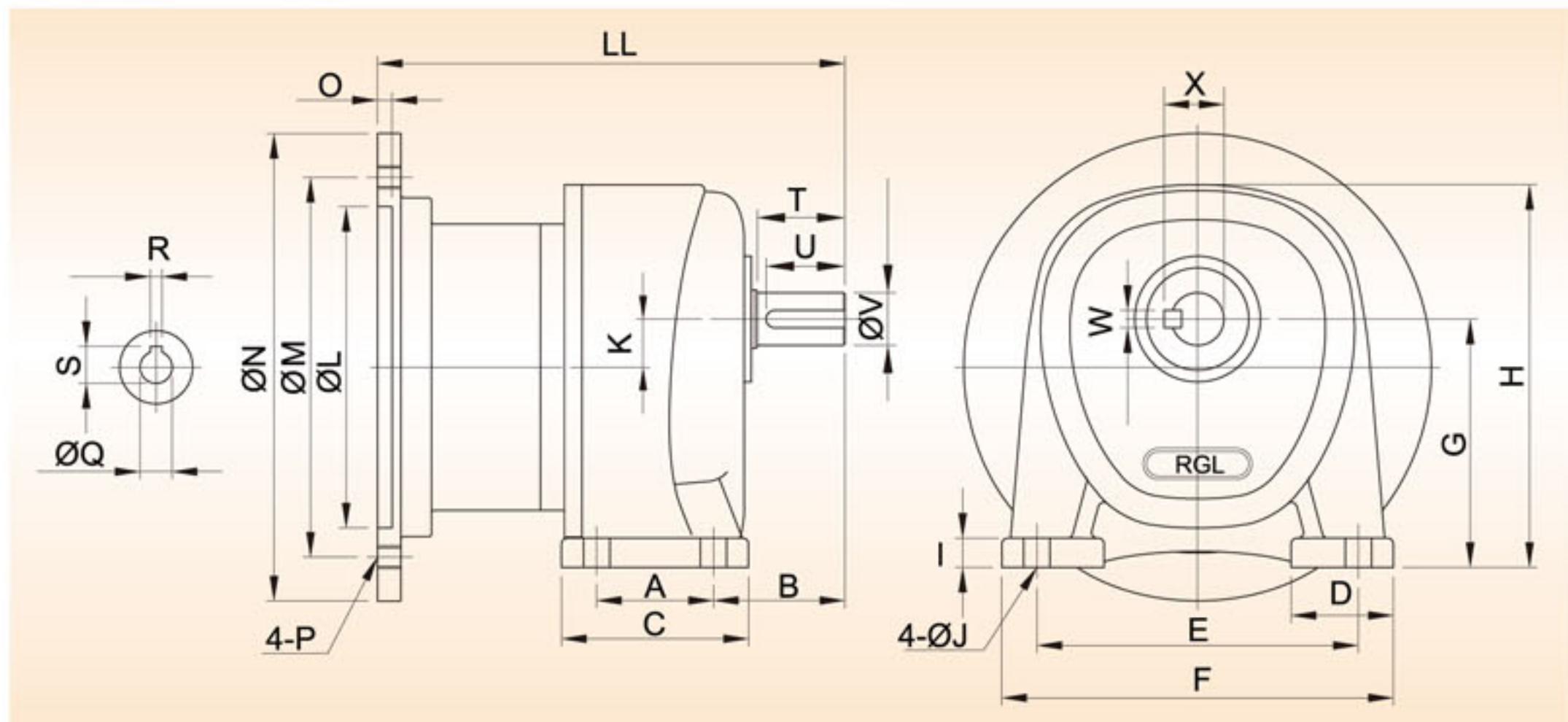

◀ Type: GLE ▶



1/8HP~5HP  
(0.1KW)



● 尺寸表 Dimensions ●

型號 SIZE	LL	A	B	C	D	E	F	G	H	I	ØJ	K
GL-18E	160	40	45	64	35	110	134	85	131	10	9	16.5
GL-22E	187.5	65	55.5	90	43	130	154	90	139	12	11	19
GL-18E	160	40	45	64	35	110	134	85	131	10	9	16.5
GL-22E	187.5	65	55.5	90	43	130	154	90	139	12	11	19
GL-28E	227.5	90	64	125	52	140	175	110	167.5	15	11	23.5
GL-22E	187.5	65	55.5	90	43	130	154	90	139	12	11	19
GL-28E	205.5	90	64	125	52	140	175	110	167.5	15	11	23.5
GL-32E	262	130	70	168	54	170	204	130	198	18	13.5	28.5
GF-28E	211.5	90	64	125	52	140	175	110	167.5	15	11	23.5
GF-32E	230.5	130	70	168	54	170	204	130	198	18	13.5	28.5
GF-40E	279	150	90	196	76	210	254	150	230	20	15	34
GF-32E	253	130	70	168	54	170	204	130	198	18	13.5	28.5
GF-40E	297	150	90	196	76	210	254	150	230	20	15	34
GF-50E	336	160	107.5	210	76	230	285	170	263.5	25	18	40
GF-40E	302	150	90	196	76	210	254	150	230	20	15	34
GF-50E	341	160	107.5	210	76	230	285	170	263.5	25	18	40
GL-50E	341	160	107.5	210	76	230	285	170	263.5	25	18	40

型號 SIZE	比數 RATIO	馬力 HP	馬達盤 MOTOR FLANGE					入力孔 INPUT HOLE				出力軸 OUTPUT SHAFT			
			ØL	ØM	ØN	O	P	ØQ	R	S	T	U	ØV	W	X
GF-18M	5~50	1/8	110	130	160	5	M8	11	4	12.7	28	27	18	6	20.5
GF-22M	60~200	0.1KW	110	130	160	5	M8	11	4	12.7	38	35	22	6	24.6
GF-18M	5~30	1/4 0.2KW	110	130	160	5	M8	11	4	12.7	28	27	18	6	20.5
GF-22M	30~100		110	130	160	5	M8	11	4	12.7	38	35	22	6	24.6
GF-28M	120~200		110	130	160	5	M8	11	4	12.7	43	40	28	8	31.4
GF-22M	5~25	1/2 0.4KW	110	130	160	5	M8	14	5	16	38	35	22	6	24.6
GF-28M	30~100		110	130	160	5	M8	14	5	16	43	40	28	8	31.4
GF-32M	120~200		110	130	160	5	M8	14	5	16	53	50	32	10	35.2
GF-28M	5~25	1 0.75KW	130	165	200	4.5	M10	19	6	21.5	43	40	28	8	31.4
GF-32M	30~100		130	165	200	4.5	M10	19	6	21.5	53	50	32	10	35.2
GF-40M	120~200		130	165	200	4.5	M10	19	6	21.5	63	58	40	12	43
GF-32M	5~25	2 1.5KW	130	165	200	4.5	M10	24	8	27.1	53	50	32	10	35.2
GF-40M	30~100		130	165	200	4.5	M10	24	8	27.1	63	58	40	12	43
GF-50M	120~200		130	165	200	4.5	M10	24	8	27.1	75	70	50	14	53.5
GF-40M	5~25	3 2.2KW	180	215	250	5	M12	28	8	31.5	63	58	40	12	43
GF-50M	30~100		180	215	250	5	M12	28	8	31.5	75	70	50	14	53.5
GF-50M	5~25	5 3.7KW	180	215	250	5	M12	28	8	31.5	75	70	50	14	53.5